

# First Experimental Demonstration of IP-client-to-IP-client Video Streaming Application over an All-Optical Label-Switching Network with Edge Routers

Junqiang Hu, Zhong Pan, Zuqing Zhu, Haijun Yang, Tinoosh Mohsenin, Venkatesh Akella, S. J. Ben Yoo  
 Department of Electrical and Computer Engineering, University of California, Davis, California 95616  
[yoo@ece.ucdavis.edu](mailto:yoo@ece.ucdavis.edu)

**Abstract:** We demonstrate, for the first time to our knowledge, successful transmission and switching of video streaming traffic from an IP-client to an IP-client over an optical label-switching network testbed.

©2005 Optical Society of America

OCIS codes: (060.4250) Networks, (060.4510) Optical communications

## 1. Introduction

IP-over-optical is a novel concept that has been actively pursued in the past several years targeting seamless integration of data and optical networking [1]. In essence, simplifying the conventional open system interconnection (OSI) layer protocol stacks including SONET and ATM, to perhaps IP directly over wavelength-division multiplexing (WDM) networking technology may provide significant cost savings in equipment and operation while offering higher performance. Optical-label switching (OLS) technology [2,3] is an attractive technology for accommodating IP-over-optical on a WDM platform using a shim layer that employs optical labels. As in MPLS networks, OLS networks require edge routers or devices to perform optical-label generation with label-distribution-protocol (LDP). Edge routers in OLS networks also function as important interfaces for IP, MPLS, ATM, or any legacy format clients or client networks. Seamless and ubiquitous IP client-to-IP client connections are potentially possible over the OLS network interfacing through the edge routers. In particular, supporting emerging applications such as video-streaming and real-time virtual reality over the OLS network will be of key importance. This paper discusses the first implementation and demonstration of IP client-to-IP client video streaming traffic transport over an optical label switching testbed with multi-gigabit data rate as well as label generating and packet aggregation edge routers.

## 2. End-to-End Testbed Description

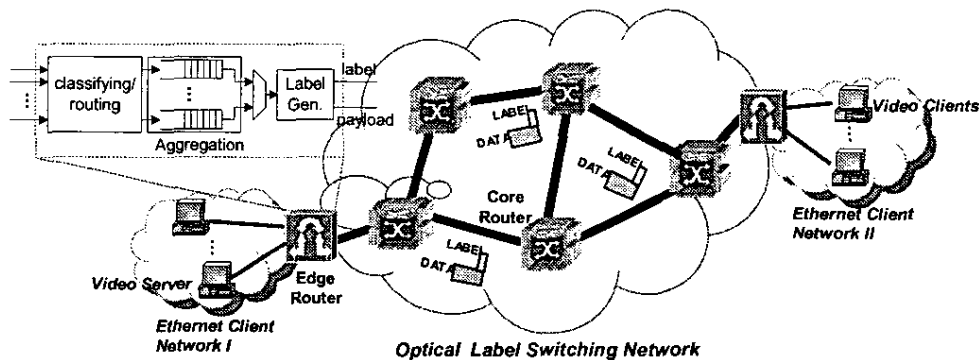

Fig. 1. IP client to IP client OLS network testbed.

Fig. 1 shows the IP client end-to-end video streaming OLS testbed architecture, which consists of the client network and the optical-label switching core network. For video streaming, the ingress path starts at the video server, enters the edge router, and then reaches the OLS core router. The egress path starts from another OLS core router, enters another edge router, and terminates at the video client. Multiple PCs can communicate by Fast Ethernet interfaces through the edge routers and the optical-label switching network.

In this testbed, we implemented the edge router to provide seamless interface between the client and core networks. On the client side, the edge router is to provide interface with legacy networks, such as IP networks and Frame Relay networks. On the core side, it provides an asynchronous packet switching interface with the optical core

router. So the edge router must provide two basic functions: IP routing and interface adapting, including protocol transformation. In our current edge router implementation, legacy networks interface with the OLS edge routers via the Fast Ethernet interfaces, while the OLS edge routers communicate with the OLS core router over 155 Mbps label interfaces and 2.488 Gbps payload interfaces. To provide different quality of service to the client applications, the edge router first classifies the packets and identifies them as different priorities. This priority will be further mapped to the priority field in the optical label, so that the optical label switching router can apply different policy. To achieve better performance, our edge router also provides maximum transport unit (MTU) adapting function. MTU adaptation occurs at the boundaries of the OLS networks to achieve high performance transport across heterogeneous underlying network technologies. Hence, at the ingress OLS edge router, legacy network packets are classified, queued and aggregated based on the packet destination and QoS/CoS class, etc. At the egress OLS edge router, optical packets are disaggregated and converted back to legacy network packets. The OLS edge router interfaces legacy protocols with OLS protocol by inserting the OLS protocol labels in the aggregated optical packet at the ingress and extracting OLS protocol labels from optical packets at the egress.

### 3. Experimental Setup

The experimental demonstration employs an OLS router testbed with the edge routers described above. Fig. 2 shows the detailed setup. A PC-based video-streaming server (VideoLAN [4] server), together with the traffic generator, generates traffic that arrives at the ingress edge router through Ethernet ports. The ingress edge router aggregates the traffic into 2.488 Gb/s payloads and generates 155 Mb/s labels for them. The SCM transmitter takes the labels and the payloads from the edge router to form SCM-labeled OLS packets, by modulating the labels onto a 14 GHz subcarrier. Upon receiving such a packet, the label extractor separates the label and the payload utilizing a fiber Bragg grating and an optical circulator [5]. The burst-mode receiver recovers the labels and forwards them to an FPGA based switch controller. Then the switch controller performs routing table look-up based on the label contents and makes switching decisions to control the tunable wavelength converter. The tunable laser tunes its wavelength following the instruction of the switch controller, and the cross-gain modulation effect in the semiconductor optical amplifier imprints the payload onto a new wavelength. The payloads from packets that have an address "0000" in the labels are converted to 1546.0 nm and the arrayed waveguide grating router (AWGR) guides them to output port I. The payloads from packets with an address "1111" are converted to 1552.2 nm and switched to output port II. The receiver at the pass-through port, consisting of an O/E converter and an electrical amplifier, converts payload back to electrical domain and sends them to the egress edge router. The egress edge router de-multiplexes the traffic streams and forwards them to the PC-based video-streaming client and the performance analyzer for performance evaluations.

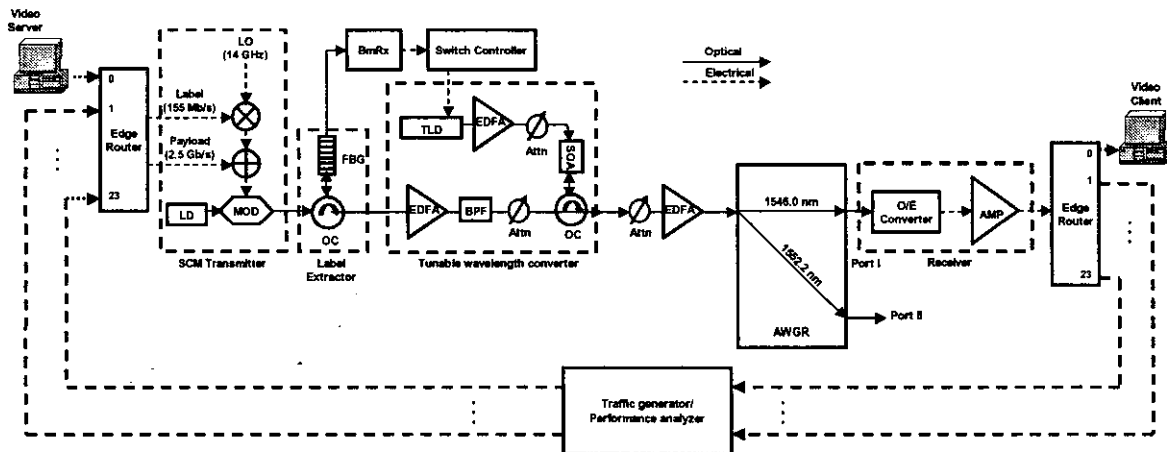

Fig. 2. Experimental setup for two-hop IP client-to-IP client communication using edge routers and an OLS core router (LD: Laser diode, Mod: LiNbO<sub>3</sub> modulator, LO: Local oscillator, OC: Optical circulator, FBG: Fiber Bragg grating, BmRx: Burst-mode receiver, TLD: Tunable laser diode, EDFA: Erbium doped fiber amplifier, BPF: Optical band-pass filter, Attn: Optical attenuator, SOA: Semiconductor optical amplifier, AWGR: Arrayed waveguide grating router, O/E converter: Optical-to-electrical converter, AMP: Electrical amplifier)

### 4. Experimental Results

Fig.3 (a) is the measured tunable laser output wavelength, indicating the two switching channels. Fig.3 (b) shows the measured packet-loss-rate (PLR) for each output channel along with packet patterns. The experimental setup

with IP-over-optical using optical label switching does not offer layer 1 or layer 2 testing since the edge router functions as a layer 3 device resulting in no layer 1 or 2 testing access. This result shows that the edge router - OLS core router combination can tolerate a relatively large power range, while still works well with a good performance.

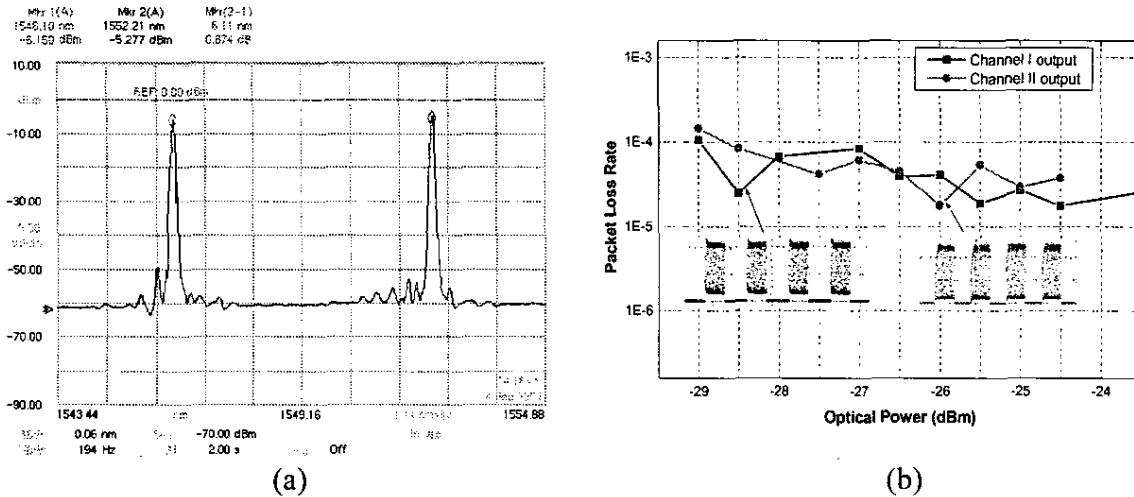

Fig. 3. Packet loss rate for IP-client to IP-client communication using edge routers and an OLS core router. (a) tunable laser output wavelength (b) packet loss rate vs. optical power

Fig. 4 shows the video streaming demonstration by different configurations: (a) IP-clients back-to-back (i.e., the two computers are connected by an Ethernet cable directly) (b) edge-routers back-to-back (the traffic will pass through the edge router, but not the optical router), and (c) through the edge routers and an OLS core router. The video quality in Fig. 4 (b) and Fig. 4 (c) are similar, which indicate that the OLS core network did not add noticeable changes in supporting the video streaming application.

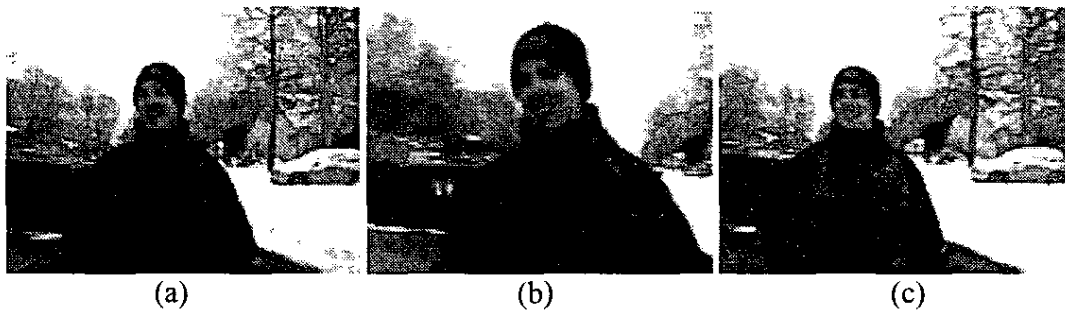

Fig. 4. Video streaming performance for IP-client to IP-client communication (a) IP-clients back-to-back, (b) edge-routers back-to-back, (c) using edge routers and an OLS core router.

## 5. Conclusion

We demonstrated, for the first time, video streaming applications from IP client-to-IP client over an optical label switching testbed. Edge routers interface the IP clients and the OLS router with low packet-error-rates. The IP client-OLS edge router-OLS core router-OLS core router- OLS edge router- IP client network supported video streaming applications with high quality.

## 6. References

- [1] DARPA BAA 98-02 Next generation internet, [http://www.darpa.mil/jpto/Solicitations/CBD\\_9802.html](http://www.darpa.mil/jpto/Solicitations/CBD_9802.html)
- [2] S.J.B. Yoo, G.K. Chang, High-Throughput, Low-Latency Next Generation Internet Using Optical Tag Switching, in U. S. Patent 6,111,673. 1997, Bellcore: U. S. A.
- [3] B. Meagher, et. al., "Design and implementation of ultra-low latency optical label switching for packet-switched WDM networks," Journal of Lightwave Technology, vol. 18, (no. 12), IEEE, Dec. 2000. p.1978-87.
- [4] VideoLAN project, VideoLAN - Free Software and Open Source video streaming solution for every OS!, (VideoLAN.org, 2004), <http://www.videolan.org>.
- [5] H. J. Lee, S. J. B. Yoo, V. K. Tsui, and S. K. H. Fong, "A simple all-optical label detection and swapping technique incorporating a fiber Bragg grating filter," IEEE Photonics Technology Letters, vol. 13, pp. 635-7, 2001.